

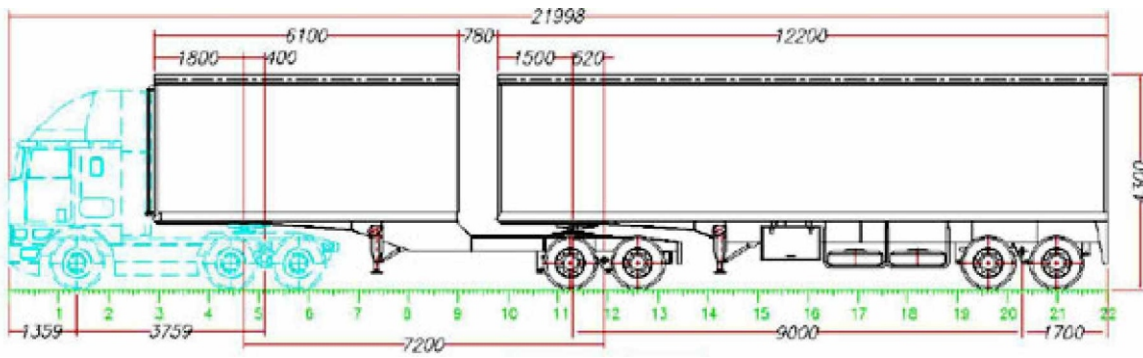

PAYLOADER

**Specification : New Tandem Tandem axle Pantechicon
super link combination**

Tare	App. 13 360kg
Payload	App33 000 kg
Length	Front 6100mm Rear 12200mm
Width	2600mm (external) 2540mm (Internal)
Height	2800mm (with horse 5 th wheel at 1270) Maximum 2750mm (with horse 5 th wheel at 1320) Maximum
Chassis	Fabricated "I" beam construction with high tensile top and bottom flanges (30 Oak)
Floor	4mm mild steel with cross members below floor spaced 250mm apart to suit forklift driving on floor with channel type side rails.
Leg gear	Payloader York heavy duty 2 speed
Rubbing plate	8mm apron plate with 50mm king pin
5 th Wheel	Payloader York
Axles	Payloader propar 127 round axles
Suspension	Mechanical 7 blade
Brakes	Haldex ABS brakes with auto slack adjusters
Spare wheel carrier	1x basket type
Toolbox	2x Standard 900x600x600 fitted 1 to front and 1 to rear link
Lights	LED type fitted as standard item with steel or plastic type tailboards and standard under run bumpers.



This drawing is the property of Payloader and cannot be copied or is closed to a third.

Company Details

160, South Rand Road, Tulisa Park, Johannesburg, South Africa
www.thepayloader.com
Email: info@thepayloader.com

Phone

(T) 27 11 8695551
(F) 27 11 8695632

Marketing Division

1st Floor, 269 Oxford Road, Illovo, Johannesburg, South Africa

(T) 27 11 2686900